

INTELLIGENT PERMANENT MAGNET VARIABLE FREQUENCY BOOSTER PUMP

INSTRUCTION MANUAL



- Before installing and using the product, please carefully read the instruction manual and keep it properly;
- Before using the electric pump, it must be reliably grounded and a leakage protection device should be installed;
- It is strictly prohibited to run the electric pump dry;
- It is strictly prohibited to operate the electric pump for dehydration.

CATALOGUE

1. Product Overview -----	2
2. Operating Conditions -----	2
3. Installation Dimensions -- -----	3
4. Exploded View -----	3
5. Application Scenarios -----	4
6. Instructions for Use -----	5
7. Important Notes -----	7
8. Maintenance -----	8
9. Fault phenomena and treatment methods -----	9

Thank you for choosing our company's product. Please read the instruction manual carefully before installation and use, and keep it properly.



Warning:

- Before using the electric pump, it must be reliably grounded, and a leakage protection device should be installed.
- It is strictly prohibited to touch the electric pump during operation.
- It is strictly prohibited to operate the electric pump without water (dry running).



Prohibited User Warning:

Children or persons with limited capacity must not use this product without supervision.



Pressure Warning:

The pipeline transportation system where the pump is located must be able to withstand the maximum pump pressure (1.0MPa).



Modification Warning:

The manufacturer shall not be liable for any consequences caused by the user's unauthorized modification of the electric pump or operation of the electric pump beyond the allowable operating conditions.

1. Product Overview

Intelligent Permanent Magnet Variable - Frequency Booster Pump (hereinafter referred to as the electric pump) adopts a permanent - magnet motor, a centrifugal impeller and a diffuser structure. The electric pump features stable operation, low noise, no leakage, anti - condensation, and simple operation.

2. Operating Conditions

1. Transport clean water medium;

2. Ambient temperature: 2°C to +40°C; Medium temperature range: 2°C to +60°C;
3. Altitude shall not exceed 1000m;
4. The pH value of the medium is between 6.5 and 8.5;
5. The volume ratio of solid impurities in the medium does not exceed 0.01%, and the particle size is not larger than 0.1mm;
6. The voltage is single - phase AC 220V, and the voltage fluctuation range is $\pm 12\%$ of the rated value.

3. Installation Dimensions

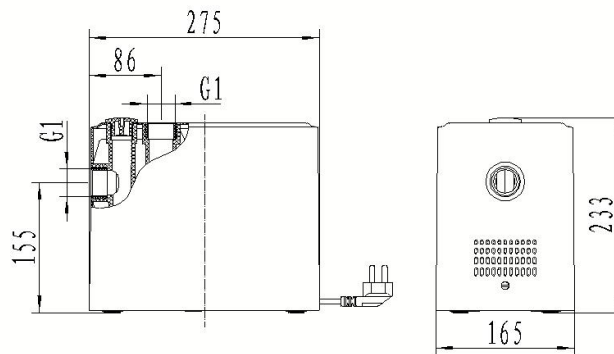

4. Exploded View

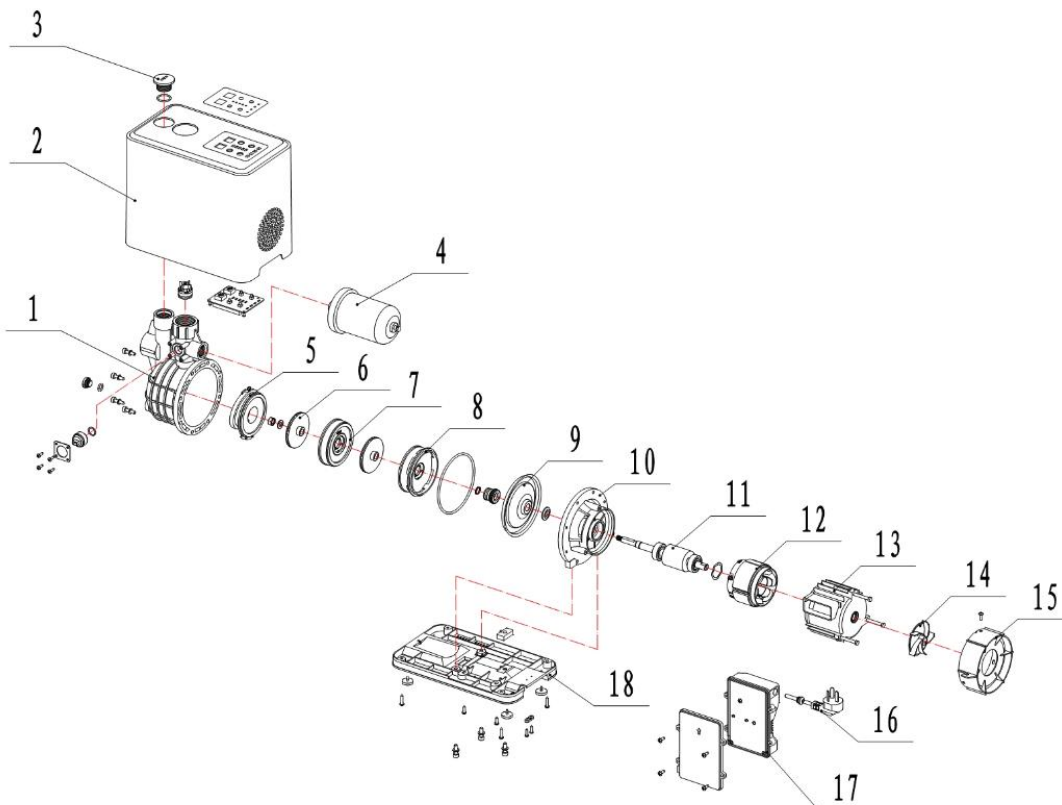

1	Pump Body	2	Shield Cover	3	Filling Plug	4	Pressure Tank
5	Inlet Section	6	Impeller	7	Diffuser casing	8	Final - stage Diffuser Shell
9	Pump Cover	10	Bracket	11	Rotor	12	Stator Core
13	Motor Housing	14	Fan Blade	15	Fan Cover	16	Plug Wire
17	Terminal Box Assembly	18	Bottom Plate				

5. Application Scenarios

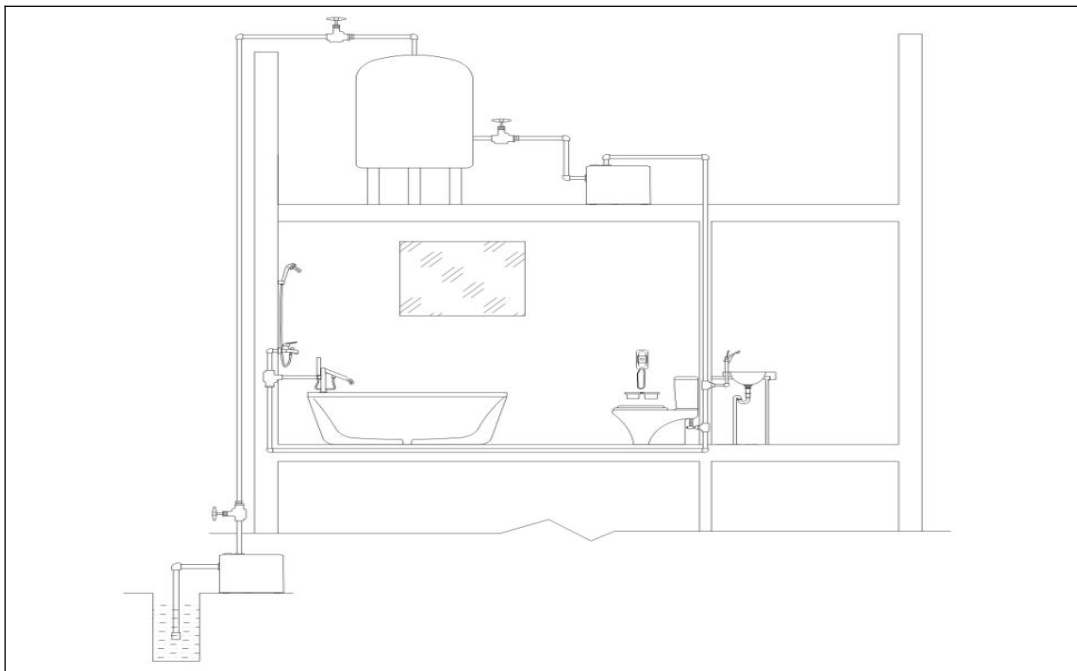

Pumping well water and pressurizing for lower floors

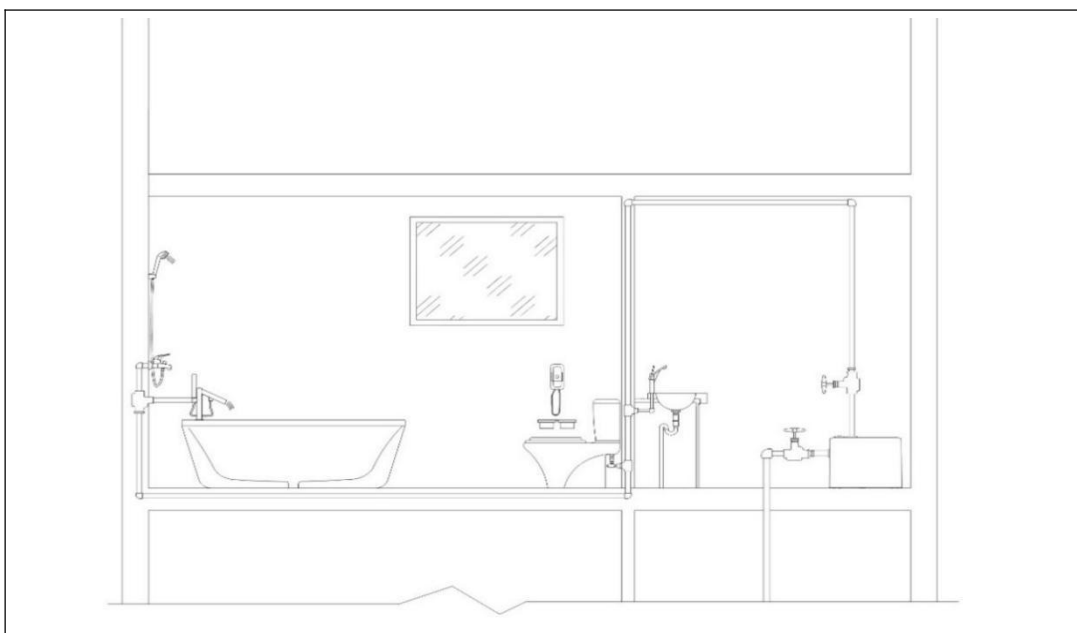

Pressurizing tap water

6. Instructions for Use

(1) Panel Schematic Diagram

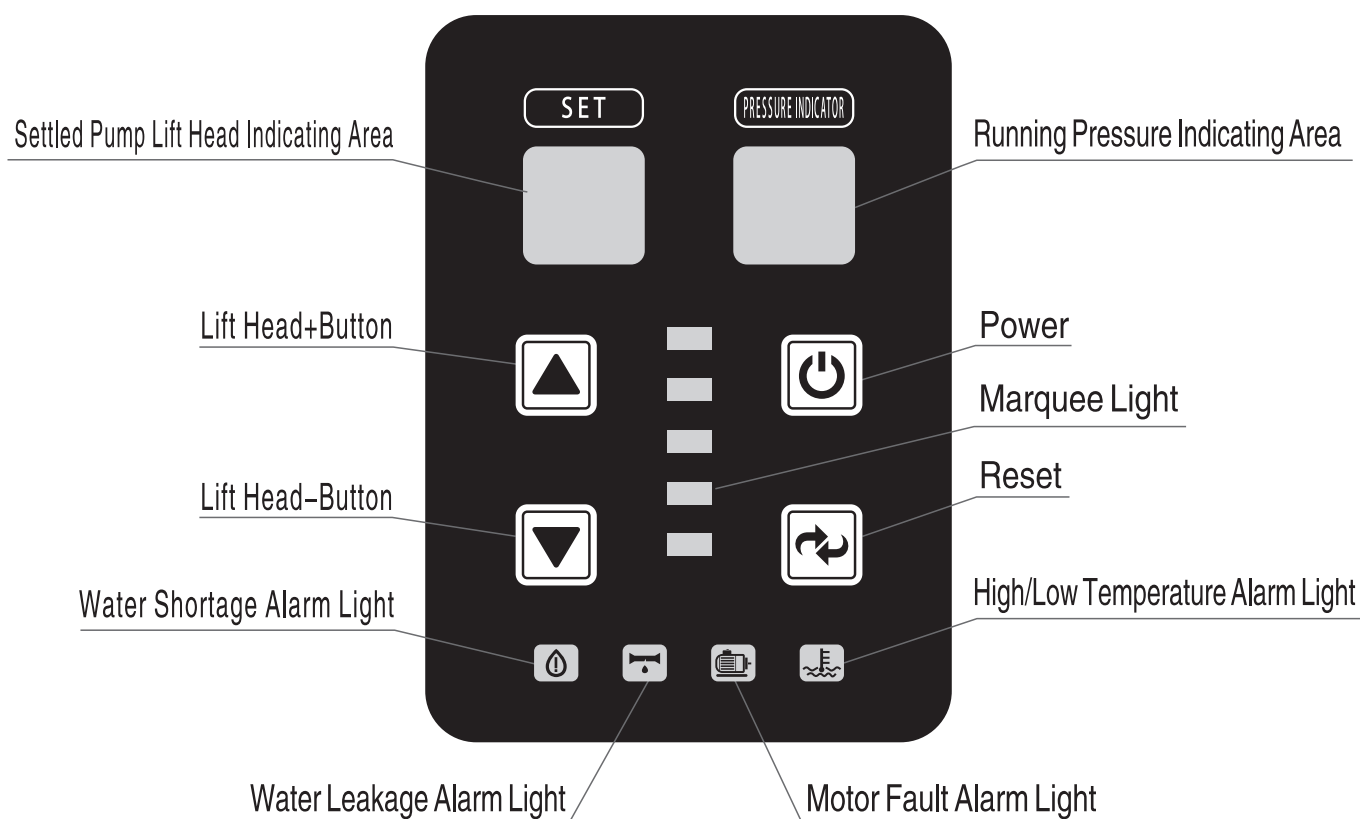

(2) Key operation instructions

Key	Description	Remark
Power switch	<ol style="list-style-type: none"> 1. Press the "power button" for a short time, the water pump is turned on, and the marquee lights up; 2. Press the "power button" for a short time again, and the water pump is on standby; 3. Long press the "power button" for 3 seconds to bypass the dry-run protection and enter self-priming mode, the speed slowly increases. 	In the startup state, when the system detects that the faucet is turned on, the water pump automatically starts; when the faucet is turned off, the water pump automatically stops.
resetting key	Press and hold for 3 seconds to restore factory settings	
▲	Short press to adjust the pump set pressure, up to 60 meters (Pump lift plus incoming water pressure)	
▼	1. boot state, short press to adjust the pump set pressure, the lowest can be reduced to 10 meters.	<ol style="list-style-type: none"> 1. motor speed; 2. pump power; 3. controller temperature;

	2. In the power-on state, press and hold for 3 seconds to enter the parameter menu of the pump. In the parameter menu mode, press and hold to switch the operating parameters.	4. water temperature; 5. input voltage; 6. software version; 7. restore display
--	--	--

(3) Description of display area

Display area	Description
Set pressure display area	The higher the set pressure, the higher the lift, up to 60 meters.(Pump lift plus incoming water pressure)
Operating pressure display area	Real-time display of pump outlet pressure
ticker	Start running lights after starting, the greater the power, the more lights

(4) Description of fault alarm lamp

Alarm lamp	Description
water shortage alarm	1. Pump no-load operation for 10 seconds, alarm light on 2. Pump running for 3 minutes, if not normal water, alarm light on
water leakage alarm	If the pipeline leaks, the pump starts and stops repeatedly, and the alarm light is on.
Motor fault alarm	If the motor has faults such as blocked rotation, overcurrent, lack of phase, high and low voltage, high temperature of control board, etc., the alarm lamp will light up.
High and low temperature alarm	1. If the water temperature exceeds 70°, the alarm light will light up and the electric pump will stop automatically. 2. When the water temperature is lower than 4° and below, the electric pump starts automatically and the alarm lamp flashes when it meets the power-on and automatic mode.

(5) Protection function

Function	Function description
Locked-rotor protecting	Motor stall occurs, motor fault alarm light on, electric pump shutdown. After 3 seconds, it automatically tries to restart. After 5 attempts, the electric pump stops completely.
Open-phase protection	The motor is out of phase, the motor fault alarm light is on, and the electric pump stops. The system will automatically attempt to restart after 60 seconds. If the fault persists after 5 attempts, the pump will shut down completely.
Overcurrent protection	Motor short-circuit overcurrent, motor fault alarm light, electric pump shutdown.

	After 60 seconds, it automatically tries to restart. After 5 attempts, the electric pump stops completely.
No-load protection	When there is no water in the pump cavity, the motor runs dry for 10 seconds, the water shortage alarm lamp lights up, and the electric pump stops.
Water shortage protection	There is water in the pump cavity, but the electric pump still cannot produce water after 3 minutes of operation. The water shortage alarm light is on, and the electric pump stops. Restart 5 minutes after the first time, 2 hours after the second to fourth times, and every 6 hours after the fifth time.
Leak protection	Detection of pipeline leakage, will not affect the normal use of the pump, only in the valve is completely closed, the pump frequently start and stop to remind users.
Low-voltage protection	When the power supply voltage is lower than 150 V, the motor fault alarm lamp lights up, the electric pump stops, and the detection voltage is higher than 170V to recover.
Overvoltage protection	When the power supply voltage exceeds 270 V, the motor fault alarm lamp lights up, the electric pump stops, and the detection voltage recovers below 260 V.
High temperature protection	When the water temperature exceeds 70° C, the high and low temperature alarm lights up, and the electric pump stops automatically. The water temperature drops by 10 degrees and automatically recovers.
Antifreeze protection	Water temperature is lower than 4°, high and low temperature alarm lights flash, electric pump automatic start, prevent pump cavity is frozen. After the water temperature rises to 7° C, return to standby mode. If the water pump has been raised less than 7°, the shutdown detection will continue to start for 10 minutes, and the water temperature will continue to reciprocate until the water temperature reaches 7°. The shutdown detection will take about 3-5 seconds.

7. Important Notes

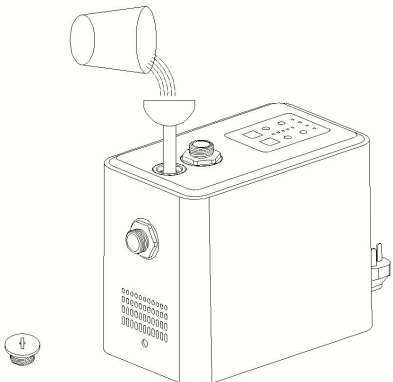
Graphic illustration	Description of usage
	<p>Before the pump is used for the first time, it is necessary to open the injection screw plug, fill the pump cavity with water, drain the air, install the injection screw plug in place, and then start the pump. When pumping well water, if water cannot be pumped for 3 minutes, open the water injection screw plug after the water shortage protection shutdown of the pump, fill the pump cavity with water, restart the pump, repeat the operation for 2~3 times until the pump normally discharges water.</p>

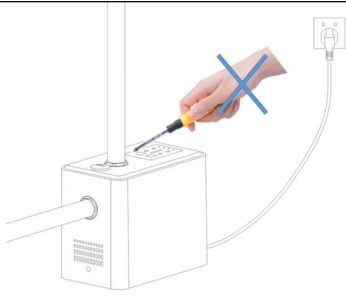
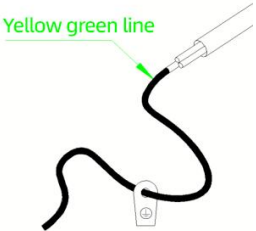
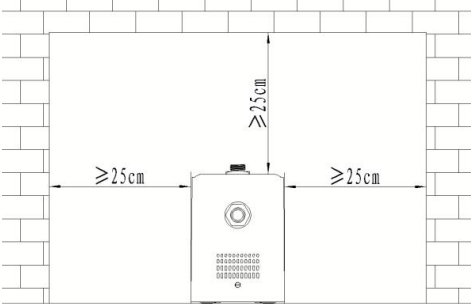
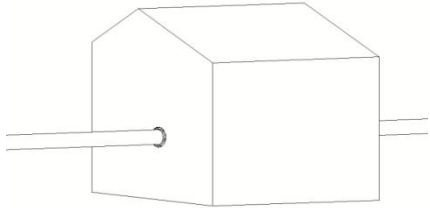
	<p>Pump work, if you want to adjust the pump position or touch the pump action, you must first cut off the power supply to prevent accidents.</p>
	<p>The leakage protection device should be installed correctly for the water pump, and reliable grounding should be carried out at the grounding mark of the water pump or cable, and the connected power socket should also be reliably grounded at the same time.</p>
	<p>Water pump installed in a place convenient for maintenance, inspection, and keep dry; in a narrow place to install water pump, to install as shown in the left, in order to facilitate heat dissipation.</p>
	<p>It is forbidden to use the pump in water. For outdoor installation, proper shelter is required to protect against sun, rain and frost. Installed indoors, it is necessary to set up drainage ditches around the pump to form natural drainage to prevent water leakage caused by loss during use, maintenance and replacement of the pump.</p>

8. Maintenance

1. Regularly check the insulation resistance of the pump, after a long time of work, its insulation resistance shall not be lower than $5M \Omega$, otherwise technical support must be sought, and it can only be used after meeting the requirements.

2. If the pump is not used for a long time, remove the pipeline, loosen the internal drain plug with a flat screwdriver, drain the accumulated water in the pump, wipe the main parts clean, place them in a dry and ventilated place, and keep them properly.

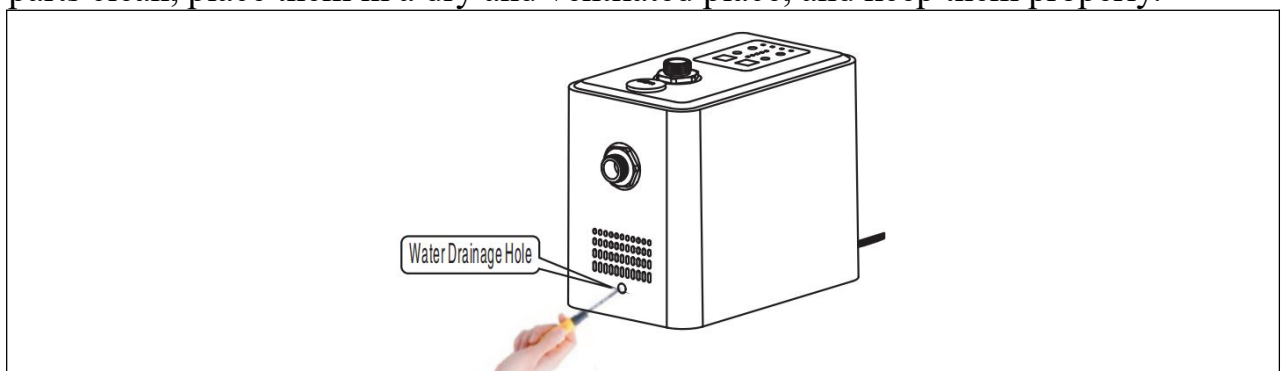

9. Fault phenomena and treatment methods

1. Water pump failure

fault phenomenon	primary cause	handling method
Motor does not rotate	<ol style="list-style-type: none"> 1. water pump cable poor contact or fracture 2. Impeller stuck 3. Stator winding burned out 	<ol style="list-style-type: none"> 1. check the terminal or replace the new cable 2. Correct stuck parts or remove impurities 3. Send to maintenance unit for maintenance
The motor runs, but the pump doesn't produce water.	<ol style="list-style-type: none"> 1. Air leakage in inlet pipeline 2. Check valve not open or blocked 3. Air enters through seals 4. Pump not full 5. damaged impeller 	<ol style="list-style-type: none"> 1. Check whether the sealing of water inlet pipeline and joint is intact. 2. Check check valve flexibility and remove blockages 3. Adjust or replace new seals 4. Refill the pump with water 5. replace the vane
insufficient flow	<ol style="list-style-type: none"> 1. Too long pipe, too high lift or bent pipe 2. Filter screen or impeller partially blocked 3. Impeller badly worn 	<ol style="list-style-type: none"> 1. Shorten the pipeline, use according to the lift range or make the pipeline bend gently 2. Remove clogging debris 3. replace the vane
intermittent start of pump when no water is used	<ol style="list-style-type: none"> 1. Water leakage from outlet pipe and faucet 2. Check valve entangled with foreign matter or check valve failure 3. Pressure tank under pressure or damaged failure 	<ol style="list-style-type: none"> 1. Check whether the outlet pipe leaks and the faucet is closed tightly 2. Clean check valve or replace with new check valve 3. Use a pump to increase the pressure of the air tank moderately or replace the new pressure tank
Motor vibration, noise	<ol style="list-style-type: none"> 1. Insufficient water intake or air leakage at inlet 2. Pump not installed horizontally or installed unevenly 3. bearing damage 	<ol style="list-style-type: none"> 1. Increase the inlet diameter or replace the inlet pipeline with a rigid pipe and reseal the connection. 2. Re-install horizontally, install shock pad under foot 3. replace the bearing

2. Common fault codes and troubleshooting

Fault code	Corresponding fault	Trouble removal
E01	communication failure	<p>Panel and motherboard communication failure.</p> <p>Check whether the connection between motherboard and panel is poor.</p>

E02	locked-rotor (Motor fault indicator light on)	<p>Check whether the motor is stuck.</p> <p>Solution:</p> <ol style="list-style-type: none"> 1. Automatic restart attempt after 1 or 3 seconds, try 5 times 2. Press the power button to restart and resume operation.
E04	pressure sensor fault	<p>Check whether the pressure sensor is damaged and the signal wire is connected properly.</p> <p>Solution:</p> <ol style="list-style-type: none"> 1. Clean up the interface wiring. 2. Replace the pressure sensor.
E05	Step loss	<p>Sudden excessive load impact, motor parameters do not match.</p> <p>Solution:</p> <ol style="list-style-type: none"> 1. Automatic restart attempt after 1 or 3 seconds, try 5 times 2. The user presses the power button to restart recovery.
E06	Phase loss(Motor fault indicator light on)	<p>Check whether the motor three-phase connection is good, whether the motor is disconnected.</p> <p>Solution:</p> <ol style="list-style-type: none"> 1. Automatic restart after 60 seconds, try 5 times 2. The user presses the power button to restart recovery.
E07	overcurrent (Motor fault indicator light on)	<p>Check motor for short circuit. Whether there is water at the motor wiring.</p> <p>Solution:</p> <ol style="list-style-type: none"> 1. Automatic restart after 60 seconds, try 5 times 2. The user presses the power button to restart recovery.
E09	pump no-load (Water shortage indicator light on)	<p>There is no water in the pump cavity.</p> <p>Solution:</p> <p>Add water to the pump and press the power button to restart.</p>
E10	Water pump water shortage (Water shortage indicator light on)	<p>There is water in the pump cavity of the water pump but no water at the inlet or too little water at the inlet.</p> <p>Solution:</p> <ol style="list-style-type: none"> 1. Current pressure drops more than 3 meters or current pressure rises more than 3 meters 2. Regular restart after shutdown

		3. The user presses the power button to restart recovery.
E11 (Not shown)	leakage indicator (Leakage indicator light on)	Leakage in pipeline was detected and pump was started and stopped frequently. Solution: 1. The pressure does not drop for 10 minutes 2. Continuous operation for 180 seconds without shutdown 3. The user presses the power button to restart recovery.
E12	Driver Overtemperature	Controller power module temperature detection greater than 85 degrees. Solution: the temperature drops below 70° recovery
E13	drive temperature sensor fault	IPM built-in temperature sensor signal loss.
E14	Low voltage protection	Detection voltage below 150V, shutdown protection. Solution: The detection voltage is higher than 170V and the recovery time is 3 seconds.
E15	voltage high voltage protection	The detection voltage exceeds 275V, shutdown protection. Solution: The detection voltage is lower than 268V and the recovery time is 3 seconds.
E18	Water temperature protection (Temperature alarm indicator on)	Water temperature higher than 70 degrees shutdown protection. Solution: the water temperature drops 10 degrees automatically restored.
E19 (Not shown)	Low temperature protection (Temperature alarm indicator flashing)	Water temperature below 4 degrees, pump running at low speed. Solution: 1. The water temperature rises by 7 degrees to recover. 2. 10 minutes forced recovery.
E20	temperature sensor failure	Water temperature sensor open or short. Solution: Replace or reconnect the water temperature sensor.

